

W/O FLIPPER
OTTM HDW
ALLOWS FOR A
TALLER
MAIN OTTM
BOARD

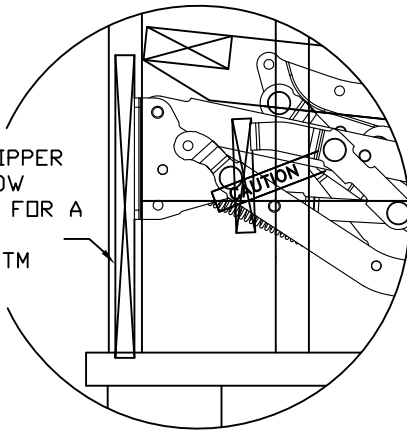

SKETCH "A"
FOR NO3 HDW

Safety Guidelines For Recliner Ottoman Manufacturers
The Joint Industry Recliner Safety Standards Committee recommends the following
Voluntary Recliner Chair Guidelines to improve the safety performance of these products.

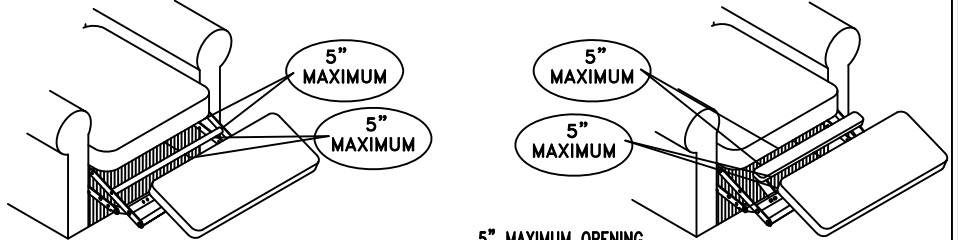

EXTRA CROSS TUBE OR BAR
may be of steel, wood or
high impact plastic

5" MAXIMUM OPENING
on either side of the tube
bar or mid-ottoman

Recliner chairs shall be so constructed as to allow no more than five inches opening between the upholstered seat rail and the upholstered leg rest in the area bounded by the parallel linkage of the extended leg rest. This may be accomplished by the use of rigid cross members or any other practical method, or in the alternative, the leg rest shall be so constructed that it will disengage when obstruction is encountered as the leg rest is closed.

127mm = 5"

